

# L40



ASD Systems



## L40 – MULTIFUNCTION AUTOMATED MACHINE FOR DISTRIBUTION OF LARGE-SIZE PRODUCTS

The self-service L40 machine is designed for **automatic distribution of up to 40 different products**. A **simple, square construction** enables you to load **large-sized products**. Specially designed openings in the back of the shelves allow for **internal 230V installations** to supply power to the stored products. **Intuitive management** is provided through a display with 15 touch sensitive buttons. You can connect a **bar code reader** to the machine.

**L40 automated machine successfully functions as an ancillary unit of D540 and D1080 automated machine.**

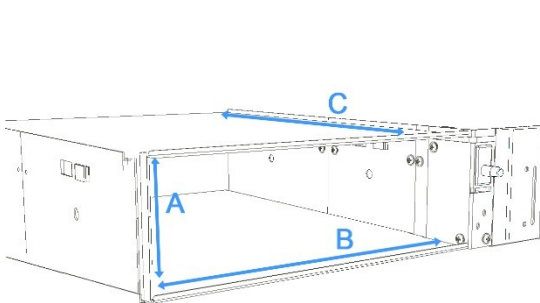
 <p>Dimensions in mm</p>	A	B	C
	80	400	586
	170	400	586
	260	400	586
	350	400	586

### Shelf adjustment function

Through the shelf adjustment function – **adjustment of height, in 4 sizes**, the machine can be loaded with up to 40 products at the same time. Easy arrangement of shelves enables clients to **adjust the capacity of the machine** to meet the current needs **whenever necessary**.

### Technical parameters

	L40M	L40S
<b>Height</b>	1940	
<b>Width</b>	1020	
<b>Maximum load per shelf</b>	25kg	
<b>Depth</b>	600	600
<b>Number of one shelf type</b>		
80 x 400 mm	35	40
170 x 400 mm + 80 x 400 mm	17 + 1	20
260 x 400 mm + 80 x 400 mm	10 + 5	12 + 2
350 x 400 mm + 80 x 400 mm	8 + 3	10
<b>Other</b>		
Operating temperature (°C)	5 – 40	
Weight (kg)	180	180
Electricity consumption (Watt)	15	
Voltage (V)	230/1A	